

**The BG Radia R-550** ribbon array loudspeaker is a breakthrough in high-performance compact line array technology.

The speaker is comprised of a line array of six (6) patented BG planar ribbon transducers covering mid- and high-frequency range and four (4) 5.25" Neodymium motor mid-woofers handling bass and extending the system's useful low frequency range down to 60 Hz.

This combination of sonically superior planar ribbon transducers and mid-woofers will comfortably handle the most demanding source material with depth, transparency and remarkable detail.

The exclusive wideband planar technology produces a cylindrical sound field, largely eliminating floor and ceiling reflections and greatly improving clarity and sonic integrity even in the most "difficult" rooms.

On top of its superior performance, the R-550 can be integrated into any décor. All these benefits, coupled with versatility and ease of installation, turn the R-550 system into a problem-solving tool for acoustically challenged rooms.

- Proprietary BG line array system with unsurpassed sound quality
- True line-source behavior based on cylindrical wave radiation
- Controlled vertical dispersion provides superior clarity by controlling floor and ceiling reflections
- Woofer dispersion integrates seamlessly with the NEO8S line array
- Extremely wide 120 degree horizontal coverage

### Applications

- Home Theaters
- Media Rooms
- Hotel Meeting Rooms
- ...and many more
- Great Rooms
- Houses of Worship
- Board Rooms





**GENERAL PARAMETERS:**

<b>System Type</b>	Two-way discrete line array in-wall loudspeaker
<b>Sensitivity<sup>1</sup> (1W/1m)</b>	92 dB
<b>Horizontal Coverage Angle<sup>2</sup> (-6 dB)</b>	120 Degrees
<b>Power Handling<sup>3</sup></b>	300 W RMS
<b>Nominal impedance</b>	8 Ohms
<b>Crossover frequency</b>	Internal passive at 270 Hz
<b>Transducers</b>	
<b>High-frequency</b>	6 x 8" Planar Ribbon Drivers (NEO8S)
<b>Low-frequency</b>	4 x 5 1/4" long throw , polycomposite cone woofers with NEO motors
<b>Dimensions (HxWx Installed D/Grille D)</b>	73 1/4" x 7 1/8" x 3 11/16" (185 cm x 17.8 cm x 9.4 cm)
<b>Wall cut-out size, HxW</b>	71 1/4" x 5 7/8" (180.4 cm x 14.9 cm)
<b>Mounting</b>	Metal dog legs with board clamping range from 3/8" to 1"
<b>Finish options</b>	Black or white (paintable)
<b>Back Box Option</b>	R-550 Back Box is recommended in all applications for best performance

1. 2.83V measured far-field and referenced to equivalent 1 m sensitivity
2. Averaged from 500Hz to 8kHz
3. Conforms to AES2 – 1984 (r1997) method

**R-550 Profile**

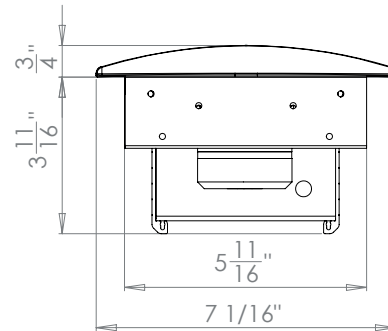

**R-550 Vertical Dispersion**

